



**Charlatte** Beltloader Model CBL2000E is capable of servicing all types of aircraft with door sill heights ranging from 30" up to 170". Power for the main drive is supplied by a 40 hp AC motor which gives the unit a 16 MPH running speed on level ground. The majority of major components are compatible with the T-137 electric baggage tractor.

**Standard Features Include:**

- **Dual Hydraulic Braking (Front - Disc, Rear - Drum)**
- **Hydraulic Power Steering**
- **Flush Mounted Belt Controls**
- **Self-Aligning Belt with Three Belt Speeds**
- **Direct Drive Belt System**
- **Modular Chassis (Gas, Diesel, and LPG available)**

# CBL2000E

## TECHNICAL CHARACTERISTICS

Manufacturer	Manufacturer		Charlatte of America	
Model	Manufacturer's Designation		CBL2000E	
Energy Source	Battery	Volts	72 or 80	
Battery Capacity	Ampere Hour Options	AH	248 / 440 / 600	
Battery Weight		lb	1872 / 2520 / 3348	
		kg	851 / 1145 / 1522	
Controller	Manufacturer		Curtis	
	Model		1238	
Converter	Manufacturer		Sevcon	
	Output Rating	Volts/Watts	13.5 / 300	
Traction Motor	Manufacturer		ABM	
	Rating @ 72 Volts	hp / kw	40 / 30	
Dimensions	Length w/o Belt Structure Guard	in / cm	300.0 / 762.0	
	Width	in / cm	86.0 / 218.4	
	Height (over steering wheel)	in / cm	58.0 / 147.3	
	Sitting Height	in / cm	35.5 / 90.2	
	Outside Turning Radius (Belt)	ft / cm	25.0 / 762.0	
	Outside Turning Radius (Chassis)	ft/ cm	23.0 / 701.0	
Performance	Speed Empty	mph / km/h	16 / 26	
	Gross Weight with Battery	lb / kg	9750 / 4432	
Chassis	Frame Mfg. W/Jigs & Fixtures		Yes	
	Auto Design Wiring Harness		Yes	
	Wheels Front/Rear		One Piece Rim	
	Tires Front	Front/Rear	225/75 X 16	
	Wheel Base C/L	in / cm	112.0 / 284.5	
	Track Width C/L Front/Rear	in / cm	69 / 175.3	
	Ground Clearance	in / cm	6.5 / 16.5	
	Service Brake Front/Rear		Disc / Drum	
	Parking Brake		Drum	
	Suspension	Front		Solid
		Rear		Two – 6 Leaf Springs
Belt Structure	Drive (Electric)	Volts	72 or 80	
	Boom Width	in / cm	31.5 / 80.0	
	Belt Width	in / cm	24.0 / 60.96	
	Roller Spacing	in / cm	6.0 / 15.2	
	Belt Height Front Max/Min	in / cm	172/436.8 – 30.0/101.6	
	Belt Height Rear Max/Min	in / cm	85.0/215.9 – 16.0/40.6	
	Belt Speed Max/Min	ft/min/cmpm	30.0/914.4 – 100.0/3048.0	
	Belt Length	in / cm	297.0 / 754.4	
	Power Roller Diameter	in / cm	9.0 / 22.9	
	Drive Axle	Manufacturer		Charlatte
Motor Drive Line			No	
Total Reduction			17:1	
Front Axle	Manufacturer		Palliard	
	Model		3390D08	

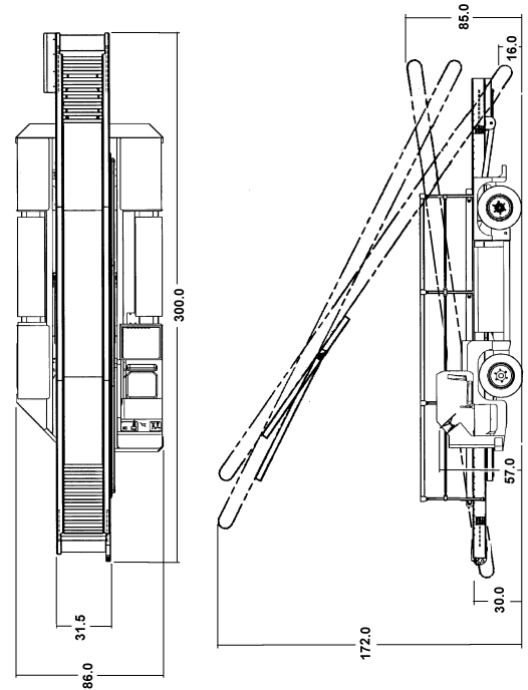

**CHARLATTE**  
G S E  
FAYAT GROUP

### Charlatte America

P.O. Box 968  
600 Mountain Lane  
Bluefield, VA 24605  
Phone: (276) 326-1510  
Fax: (276) 326-1602  
e-mail: [equipmentsales@charlatteus.com](mailto:equipmentsales@charlatteus.com)

### Charlatte France

Z.I. – Route du Boutoir  
89210 Brienon sur Armancon (France)  
Phone: (33) 386 43 01 30  
Fax: (33) 386 43 04 66  
e-mail: [contact@charlattemanutention.fayat.com](mailto:contact@charlattemanutention.fayat.com)

### Charlatte United Kingdom

LSUK Building  
Spindle Way  
RH10 1TG Crawley West Sussex  
United Kingdom  
Phone: (44) 01 293 529 640  
e-mail: [ukparts@charlattemanutention.fayat.com](mailto:ukparts@charlattemanutention.fayat.com)

These descriptions are given as an indication only and do not represent a commitment

[www.CharlatteAmerica.com](http://www.CharlatteAmerica.com)