



CBL100E

"Petite" Beltloader

Charlotte "Petite" Beltloader Model CBL100E is capable of servicing all types of aircraft with door sill heights ranging from 28" up to 90". Power for the main drive is supplied by a 9 hp DC series wound motor which gives the unit a 15 MPH running speed on level ground. The unit comes complete with an onboard charger and battery pack, including a weatherproof retractable cable reel for charging at any 110V AC source.

Standard Features Include:

- Dana Model 18 Rear Axle
- Dual Split Master Service Hydraulic Braking System
- Hydraulic Power Steering
- Belt Controls Located At Front And Rear Of Boom
- Three Belt Speeds
- Self-Aligning Belt System
- Automatic Speed Reduction (Raised Boom) On Approach To Aircraft

CBL100E

TECHNICAL CHARACTERISTICS

Manufacturer	Manufacturer		Charlotte of America
Model	Manufacturer's Designation		CBL100E
Energy Source	Battery	Volts	48
Battery Capacity	Ampere Hour Range	AH	175-275
Controller	Manufacturer		Sevcon
	Model		PowerPak
Traction Motor	Manufacturer		Advanced DC
	Model		K91-4003
	Rating	Hp / kw	4 / 3
	Rating Speed	rpm	2500
Dimensions	Length	in / mm	211.0 / 5359.4
	Width	in / mm	53.0 / 1346.2
	Height (over steering wheel)	in / mm	46.0 / 1168.4
	Sitting Height	in / mm	28.0 / 711.2
	Outside Turning Radius (Belt)	in / mm	228 / 5791.2
Performance	Speed Max (Lowered Boom)	mph / km/h	12 / 19
	Speed Max (Raised Boom)	mph / km/h	0-5 / 0-8 (Adjustable)
Chassis	Frame Mfg. W/Jigs & Fixtures		Yes
	Auto Design Wiring Harness		Yes
	Wheels Front/Rear		One Piece Rim
	Tires Front		55/80/13
	Tires Rear		55/80/13
	Wheel Base C/L	in / mm	93.5 / 2374.9
	Track Width C/L Front/Rear	in / mm	36.5 / 927.0
	Ground Clearance	in / mm	8.0 / 203.2
	Service Brake Front/Rear		Split / Hydraulic
	Parking Brake		Over center w/handle
	Suspension	Front	Leaf Spring
	Rear	Rubber Block	
Belt Structure		Volts	48
	Boom Width	in / mm	24 / 609.6
	Belt Width	in / mm	19 / 482.6
	Belt Height Front Max/Min	in / mm	90.0/2286 – 23.0/584.2
	Belt Height Rear Max/Min	in / mm	36.0/914.4 – 15.0/381
	Belt Speed Max/Min	ft/min/mpm	100.0/30.5 – 50.0/15.2
	Belt Length	in / mm	210 / 5334
Belt Drive Motor	Manufacturer		Leeson
	Model		PR990379
	Rating @ 48 Volts	Hp / kw	1.5 / 1.13
	Rating Speed	rpm	1800
Axle	Manufacturer		DANA
	Model		18
	Motor Drive Line		Yes
	Total Reduction		12.25:1

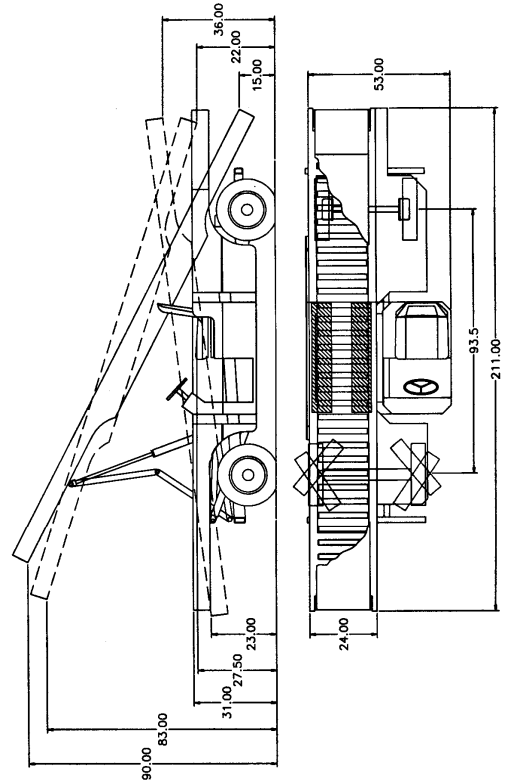

Charlotte America

P.O. Box 968
600 Mountain Lane
Bluefield, VA 24605
Phone: (276) 326-1510
Fax: (276) 326-1602
e-mail: equipmentsales@charlatteus.com

Charlotte France

Z.I. – Route du Boutoir
89210 Brienon sur Armancon (France)
Phone: (33) 386 43 01 30
Fax: (33) 386 43 04 66
e-mail: contact@charlattemanutention.fayat.com

Charlotte United Kingdom

LSUK Building
Spindle Way
RH10 1TG Crawley West Sussex
United Kingdom
Phone: (44) 01 293 529 640
e-mail: ukparts@charlattemanutention.fayat.com

These descriptions are given as an indication only and do not represent a commitment